

GY12R7 SNAP-IN TERMINAL SERIES

Datasheet

Revision 1.3, July 2023

Electrical Specifications

The GY12R7 snap-in terminal series of supercapacitors are 2.7V cylindrical cells offering excellent value, providing intermediate capacitance between radial leads and LASER weld automotive supercapacitor cells.

Part numbering code

G	Y	N	vvv	dd	mmm	S	ccc	R
Mode I	Cylindrical	no of cells 1	Voltage 2R7 = 2.7V	Diameter 30 = 30mm	Length (mm) 045= 45mm	Tolerance M \pm 20% S +50% / -20% V +30% / -10% N +20%/0% T +25% / -5%	μF Two digits + number of zeros. 157 = 150F	Lead format S = 2 pins snap-in W = 4 pins snap-in C = 2 flat tabs

Rated Voltage: 2.7V, Temperature Range: -40°C to +65°C

CAP-XX Part no.	Cap (F)	ESR _{DC} Max (m Ω)	ESR Max @ 1KHz (m Ω)	IL max ¹ @ 72 Hrs (mA)	Diameter (mm)	Length (mm)	Mass (gm)
GY12R722045V107S	100	12	8	0.3	22	45	21
GY12R722045V127S	120	12	8	0.3	22	45	21
GY12R722055V167S	160	12	8	0.5	22	55	30
GY12R725050V157S	150	11	7	0.5	25	50	30
GY12R730050V207S	200	10	6	0.7	30	50	36
GY12R730050V227S	220	10	6	0.7	30	50	39
GY12R730050V247S	240	9	5	0.7	30	50	40
GY12R735060V357C	350	3.5	3	1	35	60	73
GY12R735060V407C	400	3.2	2.8	1	35	60	73
GY12R735060V477C	470	3.5	3	1.3	35	60	73
GY12R735067V507C	500	3.4	2.9	1.3	35	67	76
GY12R735070V607C	600	3	2.5	1.5	35	70	88
GY12R740070V807C	800	3.5	3	2	40	70	115

Notes:

- DC Leakage current decays over time until it reaches equilibrium value. Value quoted is maximum after 72hrs at rated voltage and room temperature.

GY12R7 SNAP-IN TERMINAL SERIES CELL Datasheet

Applications:

- High power delivery
- Regenerative energy capture
- Improve the cycle life of large batteries
- Power smoothing for where fuel cells are used
- Load regulation for very high-power step changes

Mechanical drawing:

Note: the colour of the shrink wrap on GY product may be either Blue or Black.
All dimensions in mm

S type terminals:

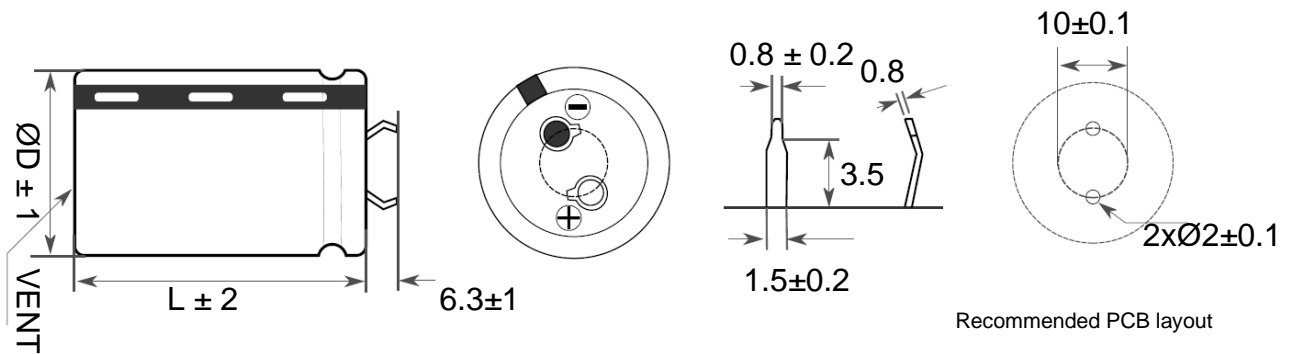

W type terminals, only available $\text{ØD} \geq 35$ mm:

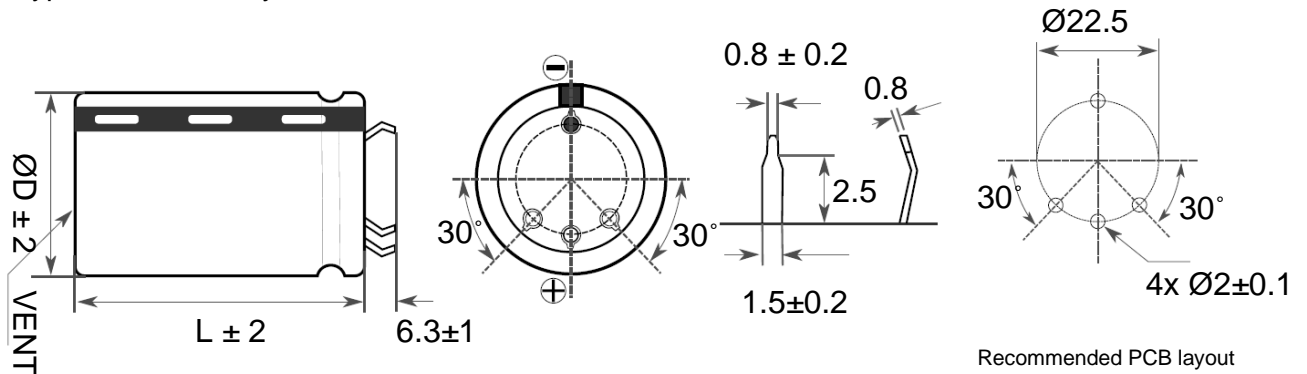

C type terminals, only available $\text{ØD} \geq 35$ mm:

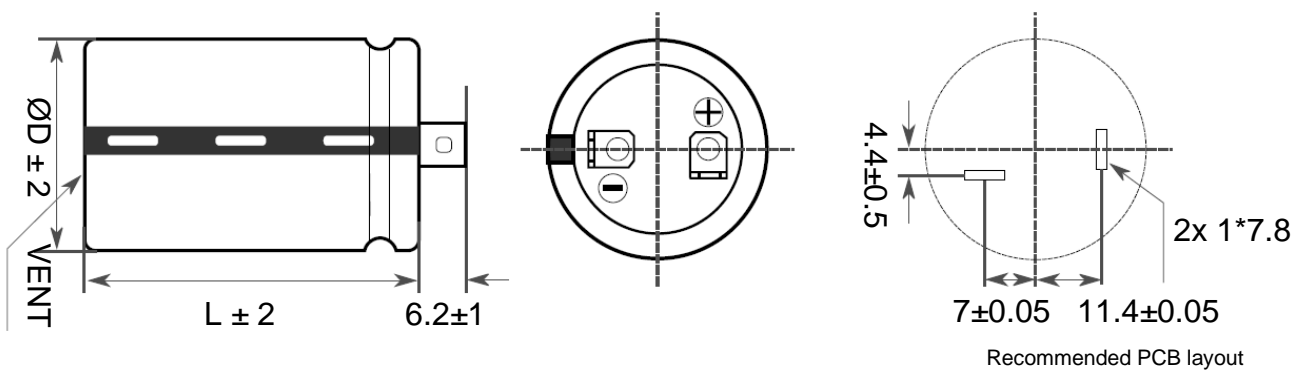

Typical long-term performance

Item		Details
Cycle Life	Test condition	Charge and discharge between V_R and $V_R/2$ at constant current for 500,000 cycles. 25°C
	$\Delta C / C_{initial}$	$\leq 30\%$
	Final ESR	≤ 2 times of initial value
Lifespan	High temperature storage	After 1000 hours storage, without charge at 70°C.
		$\Delta C / C_{initial} \leq 30\%$, $ESR_{Final} \leq 2x ESR_{initial}$
	Endurance	After 1500 hours at 2.7V, 65°C.
		$\Delta C / C_{initial} \leq 30\%$, $ESR_{Final} \leq 2x ESR_{initial}$
Projected RT life	10 years ($\Delta C / C_{initial} \leq 30\%$, $ESR_{Final} \leq 4x ESR_{initial}$)	

Note: The life performance of a supercapacitor is determined by the combination of voltage, temperature, and the duration at said condition. To get a more accurate estimate on ageing of a supercapacitor, please contact CAP-XX.

Variation in DC Capacitance and ESR with temperature

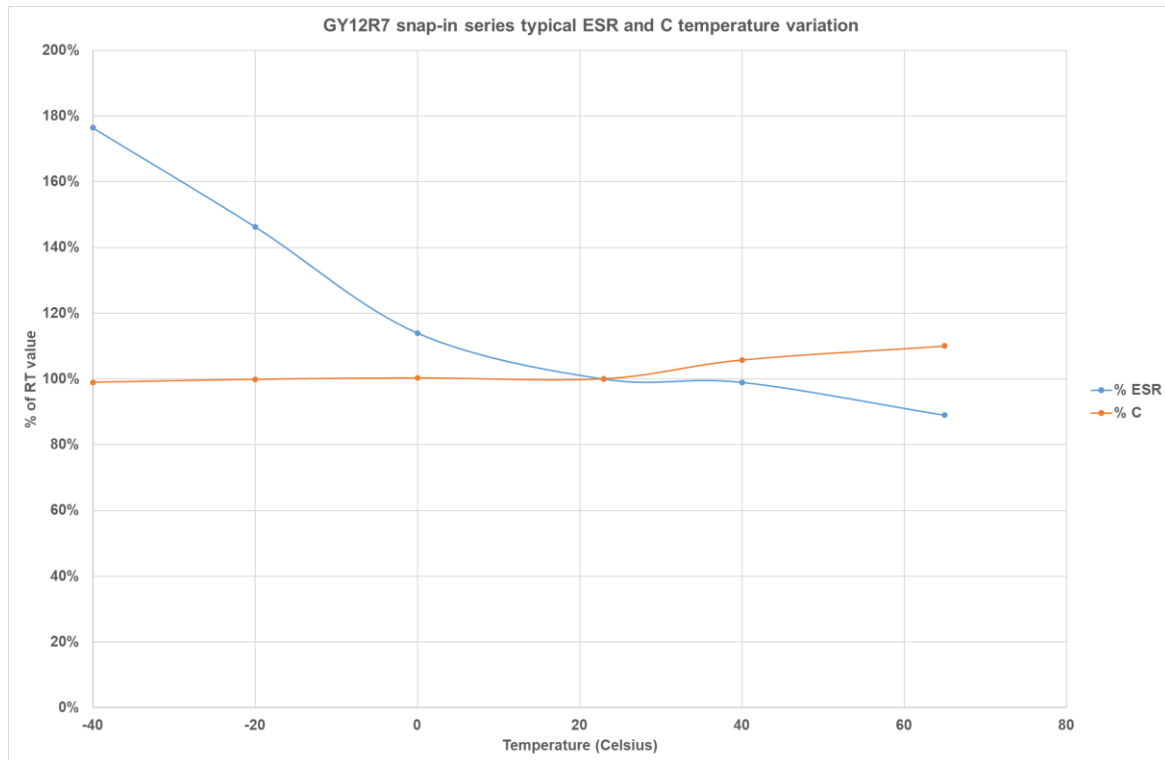

Storage

CAP-XX recommends storing supercapacitors in their original packaging in an air conditioned room, preferably at $< 30^{\circ}\text{C}$ and $< 50\%$ relative humidity. CAP-XX supercapacitors can be stored at any temperature not exceeding their maximum operating temperature but storage at continuous high temperature and humidity is not recommended and will cause premature ageing.

Do not store supercapacitors in the following environments:

- High temperature / high humidity
- Direct sunlight
- In direct contact with water, salt, oil or other chemicals
- In direct contact with corrosive materials, acids, alkalis or toxic gases
- Dusty environment
- In environments subjected to shock and vibration

Soldering

When soldering it is important to not over-heat the supercapacitor to not adversely affect its performance. CAP-XX recommends that only the terminals come in contact with solder and not the supercapacitor body.

Hand Soldering

Heat transfers from the terminals into to the supercapacitor body, so the soldering iron temperature should be $< 350^{\circ}\text{C}$ soldering time should be kept to the minimum possible and be less than 7 seconds.

GY12R7 SNAP-IN TERMINAL SERIES CELL Datasheet

Wave Soldering

The PCB should be pre-heated only from the bottom and for < 60 secs with temperature $\leq 100^{\circ}\text{C}$ on the top side of the board for PCBs $\geq 0.8\text{mm}$ thick. The table below lists suggested solder temperatures.

Solder temperature $^{\circ}\text{C}$	Suggested solder time (s)
220	7
240	7
250	5
260	3

Reflow Soldering

Reflow soldering are not recommended for this product.