

# cap-XX

## Supercapacitor Evaluation Board

### Part No. APPEB1002

# User's Manual

Revision 1.0  
January, 2003

## Supercapacitor Applications

- PDA
- Compact Flash
- PC Card
- Smartphone
- GPRS
- Handheld Equipment
- Load Leveling

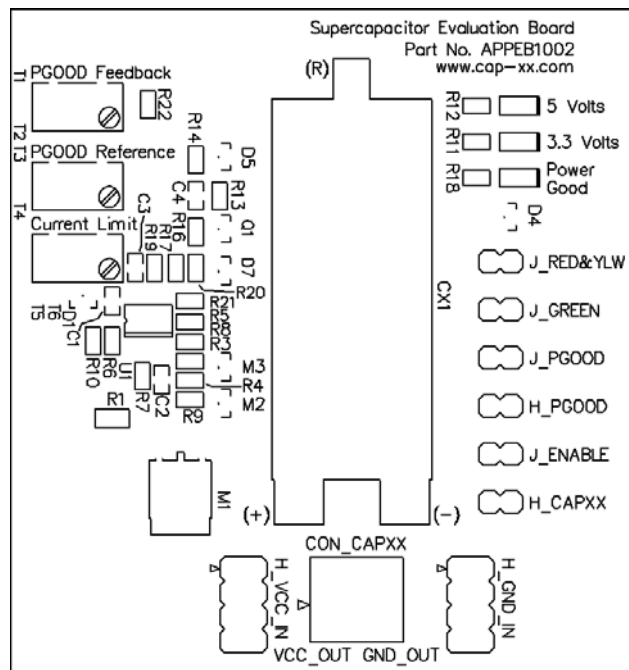

## Evaluation Board Features

- Supercapacitor (two form factors)
- Adjustable current limit circuit with Supercapacitor charge enable
- 3.3V and 5V input LEDs
- Supercapacitor voltage comparator with adjustable threshold, adjustable hysteresis and Power Good LED
- Sub-circuits can be disconnected to reduce the load
- Test points, jumpers and I/O connectors

# Contents

1.0	Introduction	3
2.0	Input Voltage	3
	<i>2.1 Charge Time</i>	3
3.0	Current Limit	4
4.0	Enable	4
5.0	Power Good	4
6.0	Adjusting the Circuit	5
	<i>6.1 Adjusting Hysteresis Width with "PGOOD Feedback" - R<sub>23</sub></i>	6
	<i>6.2 Adjusting the High Threshold with "PGOOD Reference" - R<sub>15</sub></i>	6
	<i>6.3 Adjusting the Current Limit with "Current Limit" - R<sub>2</sub></i>	7
	<i>6.4 Replacing the Potentiometers with Fixed Resistors</i>	7
	<i>6.5 Limits of Adjustment</i>	7
7.0	Connecting the Evaluation Board to a Test Platform	8
	<i>7.1 Application Hints</i>	9
8.0	Disconnecting Circuits for Reduced Load	9
	Appendix	10
	Schematic	10
	PCB Top Overlay	11
	PCB Top Layer	12
	PCB Bottom Layer	13

## 1.0 Introduction

This User's Manual is for the cap-XX Supercapacitor Evaluation Board (Part No. APPEB1002). This board was designed for the evaluation of a supercapacitor in a typical application. The application of supercapacitors is limited only by the user's imagination. Typical examples are PDA, Compact Flash, PC Card, Smartphone, GPRS and other handheld equipment.

The Evaluation Board is basically a supercapacitor with a current limit circuit that can be simply connected to a Test Platform.

An excellent source for information on Supercapacitors and free downloads are available on the cap-XX website at [www.cap-xx.com](http://www.cap-xx.com).

In the following description of operation it may be helpful to refer to the Evaluation Board Schematic in the Appendix.

## 2.0 Input Voltage

The supercapacitors for the Evaluation Board are rated at 4.5V and therefore it is not recommended that the input voltage ( $V_{CC}$ ) be greater than 4.5V. If  $V_{CC}$  is 5V then the Equivalent Series Resistance rise rate of the supercapacitor is increased and the lifetime will be reduced. A red LED is included to indicate that  $V_{CC}$  is too high and it starts to glow when  $V_{CC}$  is approximately 4.2V. The red LED is labeled on the Evaluation Board as "5 Volts". If  $V_{CC}$  is 5V then the voltage can be dropped to  $< 4.5V$  by including an external series diode in the voltage supply line of the Evaluation Board. A typical voltage for these supercapacitors is 4.2V and less, and therefore ideal for  $Li^+$  ion battery applications such as PDAs and smartphones or 3.3V PC Cards and Compact Flash (5V versions are easily accommodated by including the series diode). A yellow LED is included to indicate when  $V_{CC}$  is 3.3V or greater. It is labeled on the Evaluation Board as "3.3 Volts".

If  $V_{CC}$  is disconnected and there is still charge on the supercapacitor then current will flow through the body diode of M1 and through the yellow LED (also through the red LED if the supercapacitor is greater than  $\sim 4.2V$ ). In this case the intensity of the yellow LED gives an indication of the voltage remaining on the supercapacitor.

### 2.1 Charge Time

A fully discharged supercapacitor will be charged to  $V_{CC}$  after a certain time ( $t_c$ ). This time will depend on the current limit ( $I_L$ ),  $V_{CC}$  and the capacitance (C). The equation is

$$t_c = \frac{CV_{CC}}{I_L} \quad (1)$$

### 3.0 Current Limit

Circuits that employ large capacitors generally need a current limiting circuit to alleviate the current in-rush problem. The Evaluation Board has an adjustable current limit circuit. The current limit can be adjusted from 0A to ~ 4.5A by using the potentiometer R2. It is labeled on the Evaluation Board as "Current Limit". Turning the potentiometer clockwise will increase the current limit.

The MOSFET (M1) and Sense Resistor (R1) can withstand up to 4.5A whilst the supercapacitor is being charged. They cannot however withstand the 4.5A indefinitely. Also, there is no short circuit protection. The MOSFET (M1) has a maximum average power dissipation of 2.5W. Therefore any continuous load resistance ( $R_L$ ) has a minimum value as given by equation 2.

$$R_L > \frac{V_{CC}I_L - 2.5}{I_L^2} \quad (2)$$

### 4.0 Enable

The current limit circuit has an enable feature. *Enable* is an active low signal and the two pin jumper is labeled on the Evaluation Board as "J\_ENABLE". It is an input signal to the Evaluation Board and it can be jumpered to ground, to be permanently enabled, or it can be externally driven by an open collector or drain. When "J\_ENABLE" is externally driven it allows the supercapacitor to be charged only when the Test Platform is ready.

### 5.0 Power Good

The Power Good circuit (PGOOD) is included to indicate when the supercapacitor is charged to the appropriate level. The voltage on the supercapacitor is compared to a reference using a comparator with adjustable thresholds and hysteresis. The thresholds need to be adjustable on an Evaluation Board because different applications will require different load voltages. The hysteresis also needs to be adjustable because a step in load current will cause a step voltage on the supercapacitor because of the supercapacitor's Equivalent Series Resistance (ESR). Since this step voltage (part of the ripple) is a normal occurrence, it would not be desirable for this to indicate that the supercapacitor is undercharged.

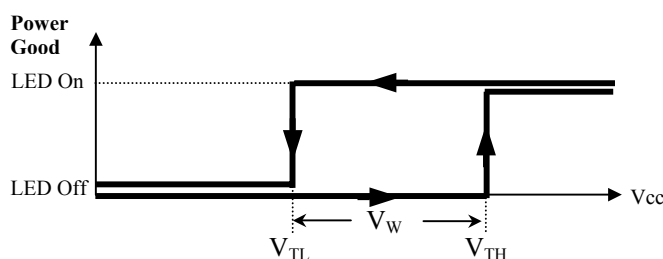

**Figure 1** Power Good Hysteresis

As in Figure 1, the high threshold ( $V_{TH}$ ) is the voltage at which the supercapacitor's unloaded voltage becomes acceptable. The hysteresis ( $V_W$ ) is the voltage that when subtracted from the high threshold gives the low threshold ( $V_{TL}$ ). It indicates that the supercapacitor is undercharged.  $V_{TH}$  is set by the factory at 3.2V and  $V_W$  is set at 0.3V, therefore  $V_{TL}$  is 2.9V.

PGOOD has a header labeled on the Evaluation Board as "H\_PGOOD". It is an active high output signal that can be used to signal an external circuit that the supercapacitor is fully charged. A green LED is also included to indicate this condition. It is labeled on the Evaluation Board as "Power Good".

## 6.0 Adjusting the Circuit

**Equipment needed:** Adjustable power supply, multi-meter and various power resistors

**Warning:** Be careful not to exceed the supercapacitor rated voltage (4.5V) or the maximum average power rating for M1 (2.5W)

Sections 6.1, 6.2 and 6.3 explain how to adjust the circuit practically and section 6.4 gives the theoretical equations.

- (a) Connect a load power resistor ( $R_L$ ) of around  $10\Omega$  from "VCC\_OUT" to "GND\_OUT" on "CON\_CAPXX". This ensures that the supercapacitor voltage will change in reasonable time when the power supply voltage is changed. Note the power rating of  $R_L$  has to be a minimum value according to equation 3.

$$P_{R_L} > \frac{V_{CC\_OUT}^2}{R_L} \quad (3)$$

- (b) Ensure jumpers "J\_RED&YLV", "J\_GREEN", "J\_PGOOD" and "J\_ENABLE" are fitted.
- (c) Turn the "Current Limit" -  $R_2$  fully clockwise (maximum current).
- (d) Turn the "PGOOD Reference" -  $R_{15}$  to around mid position (about 11 turns from either limit).

### 6.1 Adjusting Hysteresis Width with "PGOOD Feedback" - R<sub>23</sub>

**NOTE:**  $V_W$  is adjusted before  $V_{TH}$  because the  $V_{TH}$  adjustment is affected by  $V_W$ . Therefore if adjustments are made in this section then section 6.2 should be checked.

- (a) Decide the high threshold voltage  $V_{TH}$ , the low threshold voltage  $V_{TL}$  and the hysteresis voltage width  $V_W$  ( $V_W = V_{TH} - V_{TL}$ ).  $V_{TL}$  has to be greater than the minimum voltage required by the Pulsed Load.  $V_W$  has to be greater than the expected voltage droop due to the ESR and capacitor discharge etc.
- (b) Set the power supply voltage to say 3.3VDC. Ensure that the power supply can supply the desired current. Connect its negative lead to any pin on the header labeled "H\_GND\_IN". Connect the positive lead to any pin on the header labeled "H\_VCC\_IN". The LED labeled "3.3 Volts" should now be ON and the LED labeled "Power Good" should also be ON. If "Power Good" is not ON, then turn "PGOOD Reference" - R<sub>15</sub> anticlockwise slowly until the "Power Good" LED is ON.
- (c) Connect a voltmeter across the supercapacitor, which is also across R<sub>L</sub> and "CON\_CAPXX" ( $V_{R_L}$ ). Slowly reduce the power supply voltage and note  $V_{R_L}$  when the "Power Good" LED turns OFF. Slowly increase the power supply voltage and note  $V_{R_L}$  when the "Power Good" LED turns ON. The difference between the two readings is the hysteresis voltage width  $V_W$ .
- (d) Adjust "PGOOD Feedback" - R<sub>23</sub> (anti-clockwise increases  $V_W$ ) and repeat (c) above until precisely the desired hysteresis width is achieved.

### 6.2 Adjusting the High Threshold with "PGOOD Reference" - R<sub>15</sub>

- (a) Turn "PGOOD Reference" - R<sub>15</sub> fully clockwise and then reduce the power supply voltage until the "Power Good" LED is OFF.
- (b) Adjust the power supply voltage so  $V_{R_L}$  equals the desired  $V_{TH}$ . Turn "PGOOD Reference" - R<sub>15</sub> slowly anti-clockwise until the "Power Good" LED turns ON.
- (c) Check that the "Power Good" LED turns ON and OFF at the desired levels. This can be done by varying the power supply voltage in both directions so that  $V_{R_L}$  is less than  $V_{TL}$  and then greater than  $V_{TH}$ .
- (d) Remove R<sub>L</sub>.

### 6.3 Adjusting the Current Limit with "Current Limit" - R<sub>2</sub>

**Warning:** the maximum average power rating for M1 is 2.5W (see section 3.0)

- (a) Connect a load resistor to "CON\_CAPXX" (R<sub>L</sub>) that draws just over the desired current limit for the application. Note the power rating of the resistor is according to equation 3 and R<sub>L</sub> has to be a minimum value according to equation 2. For example if the supply voltage is 3.3V and the desired current limit is 1A then an R<sub>L</sub> < 3.3 Ω would draw more than 1A. According to equation 2, R<sub>L</sub> > 800mΩ. Choose say 2.7Ω (next standard value < 3.3 Ω) and equation 3 says the power rating must be greater than 4W.
- (b) With an ammeter in series with the power supply, adjust "Current Limit" - R<sub>2</sub> until the current is limited to the desired value (clockwise increases the current).
- (c) Remove the load.

### 6.4 Replacing the Potentiometers with Fixed Resistors

The potentiometers on the Evaluation Board are included to provide flexibility in evaluating many different applications. In a final design for production the resistance of the potentiometers would have been decided and therefore they can be replaced with fixed resistors. This section includes the equations that can be used to theoretically determine the value of these resistors. The value of these resistors can also be found practically by measuring the resistance of the potentiometers out of circuit once the circuit has been successfully adjusted as above.

$$R_{22} + R_{23} = \frac{55k}{V_w} \quad (4)$$

$$R_{15} + R_{16} = \frac{4k7V_{TH}}{5 + V_w - V_{TH}} \quad (5)$$

$$R_2 = \frac{22k}{\frac{56}{I_L} - 1} \quad (6)$$

### 6.5 Limits of Adjustment

From the schematic in the Appendix it can be seen that;

R<sub>22</sub>=100kΩ  
 R<sub>23</sub>=500kΩ potentiometer  
 R<sub>15</sub>=5kΩ potentiometer  
 R<sub>16</sub>=3k9Ω  
 R<sub>2</sub>= 2kΩ potentiometer

From equation 4;

$$0.1V \leq V_W \leq 0.5V$$

From equation 5;

$$2.3V \leq V_{TH} \leq 3.3V \quad (V_W=0.1V)$$

$$2.4V \leq V_{TH} \leq 3.5V \quad (V_W=0.3V)$$

$$2.5V \leq V_{TH} \leq 3.6V \quad (V_W=0.5V)$$

From equation 6;

$$0A \leq I_L \leq 4.7A$$

If these limits do not suit the application then resistors can be replaced on the Evaluation Board according to equations 4,5 and 6.

## 7.0 Connecting the Evaluation Board to a Test Platform

There are two eight pin headers on the Evaluation Board labeled "H\_GND\_IN" and "H\_VCC\_IN". These are to be connected to the ground and  $V_{CC}$  of the user's Test Platform respectively as in Figure 2. As stated earlier, if  $V_{CC}$  is 5V then the voltage should be dropped to  $< 4.5V$  by including an external series diode before the connection to "H\_VCC\_IN".

The supercapacitor terminals are joined to the connector labeled "CON\_CAPXX". The terminals of "CON\_CAPXX" are labeled "GND\_OUT" and "VCC\_OUT". These are to be connected as close as possible to the ground and positive supply of the Pulsed Load respectively. For the least voltage droop, it is important to minimise the resistance between the supercapacitor and its load. Therefore the wires from "CON\_CAPXX" to the Pulsed Load should be as short and as thick as practical.

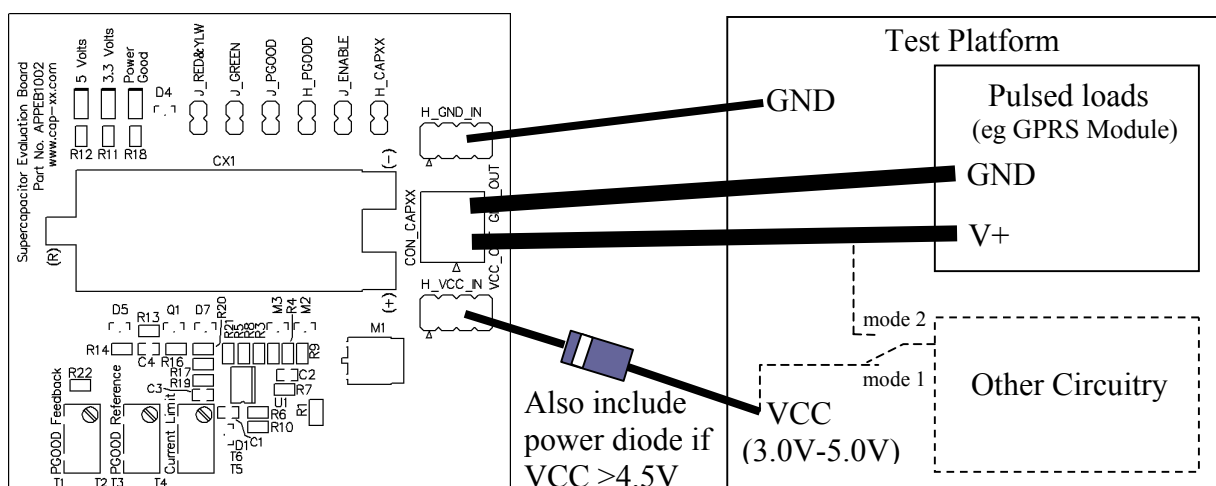

**Figure 2** Typical connection of Evaluation Board to a Test Platform

### *7.1 Application Hints*

Figure 2 shows the typical way for connecting the Evaluation Board to the Test Platform. However,  $V_{CC}$  on the Test Platform is generally used in one of two modes. Mode 1 is when  $V_{CC}$  directly supplies all the circuitry on the Test Platform ("Other Circuitry") except for the Pulsed Loads ( $V+$ ), which is supplied indirectly via the supercapacitor. In this mode  $V_{CC}$  is available to the "Other Circuitry" as soon as the Test Platform is powered up, whereas the supercapacitor supply to the Pulsed Loads is delayed by the charge up time according to equation 1.

Mode 2 is when  $V_{CC}$  is taken from the Test Platform and it only supplies the Evaluation Board. The supercapacitor then supplies the Pulsed Loads as well as the "Other Circuitry" on the Test Platform. In this mode all supplies are delayed according to equation 1.

Care must be taken, in which ever mode is chosen, so that the charge up time of the supercapacitor does not affect the operation of any reset or power rail monitoring circuitry etc. As described in section 4.0 and 5.0, the "J\_ENABLE" and "H\_PGOOD" signals may need to be interfaced with the Test Platform for proper control.

### **8.0 Disconnecting Circuits for Reduced Load**

The minimum voltage on some loads may be critical. Any current that the Evaluation Board uses contributes to the droop on the input voltage. If the droop becomes excessive then some of the functions on the Evaluation Board can be disconnected to save current and therefore increase the input voltage. The red and yellow LEDs can be disconnected by removing the jumper "J\_RED&YLW". The green LED can be disconnected by removing the jumper "J\_GREEN". The entire PGOOD circuit can be disconnected by removing the jumper "J\_PGOOD".

# Appendix

## Schematic

8 pins for VCC allow for connecting to the host as well as some test points.

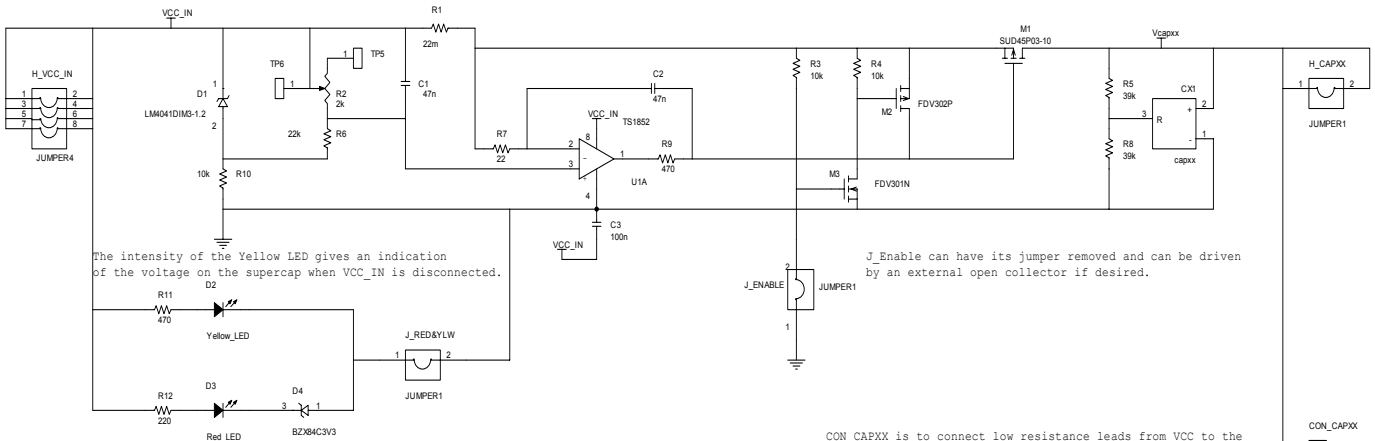

The intensity of the Yellow LED gives an indication of the voltage on the supercap when VCC\_IN is disconnected.

J\_Enable can have its jumper removed and can be driven by an external open collector if desired.

If VCC\_IN is 5V then both the Red and Yellow LEDs will be on.  
 If VCC\_IN is 3.3V then only the Yellow LED will be on.  
 These LEDs will also be powered by the supercapacitor through the body diode of the current limiting Mosfet (M1) when VCC\_IN is disconnected.  
 The LEDs can be disconnected so as to not load the circuit.

CON\_CAPXX is to connect low resistance leads from VCC to the test circuit so there is a low resistance path from the supercap to the load.

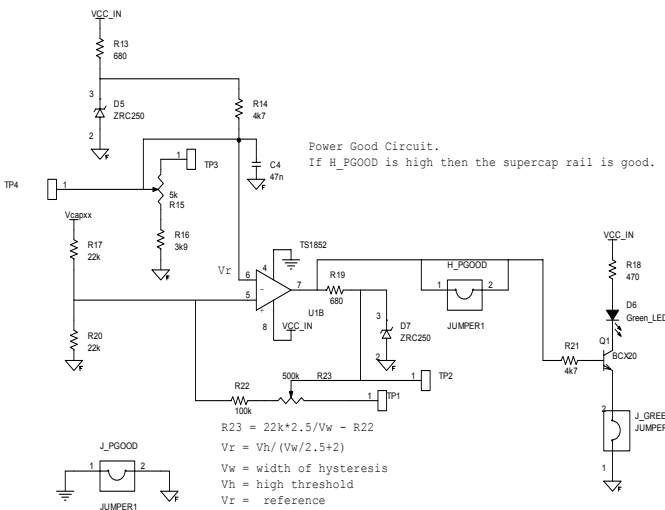

Power Good Circuit.  
 If H\_PG00D is high then the supercap rail is good.

$$R23 = 22k * 2.5 / Vw - R22$$

$$Vr = Vh / (Vw / 2.5 + 2)$$

Vw = width of hysteresis  
 Vh = high threshold  
 Vr = reference

Linking all POWER GOOD grounds and then jumpering to common ground allows the POWER GOOD circuit to be disconnected.

8 pins for H\_GND\_IN allow for connecting to the host as well as some test points.

PCB Top Overlay

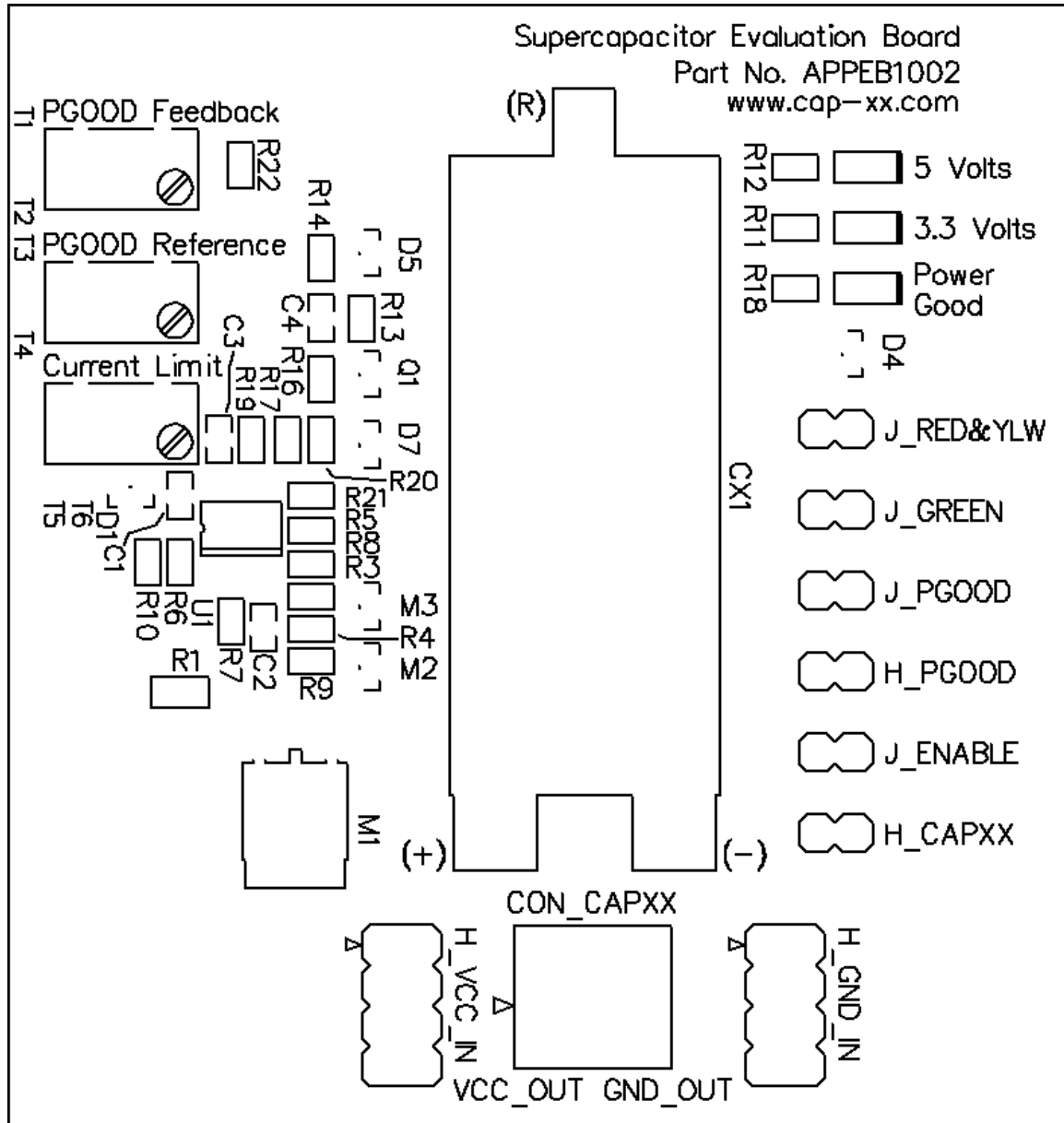

### PCB Top Layer

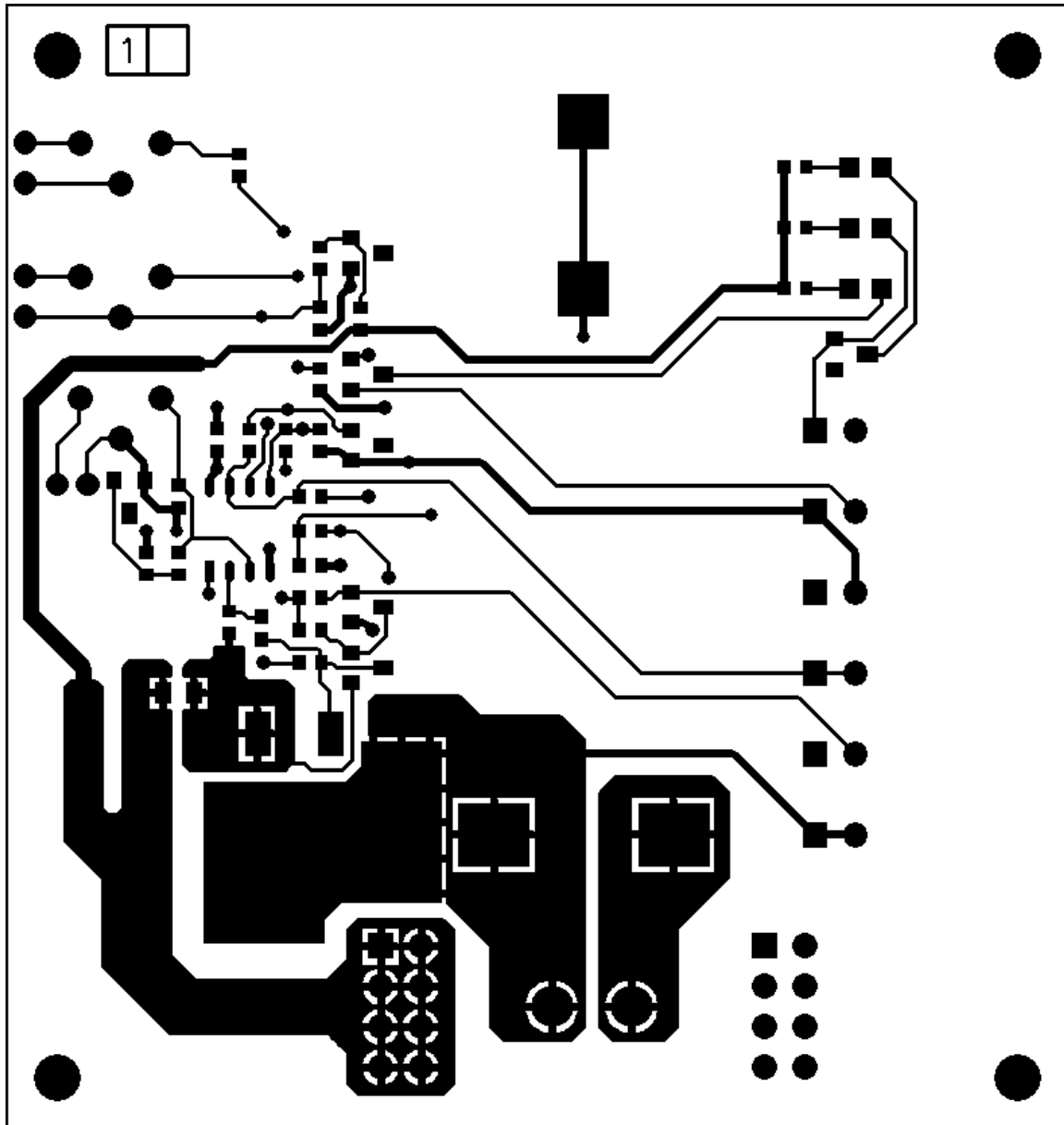

### PCB Bottom Layer

