

**cap-XX:**  
**Digital power for next  
mobile generation**

---

---

**Intel Developer Forum Spring 2001**

**George Paul, COO, cap-XX**

**Rory Pynenburg, Business Development Manager, cap-XX**

cap-XX designs and manufactures the world's most advanced supercapacitors

# cap-XX supercapacitors

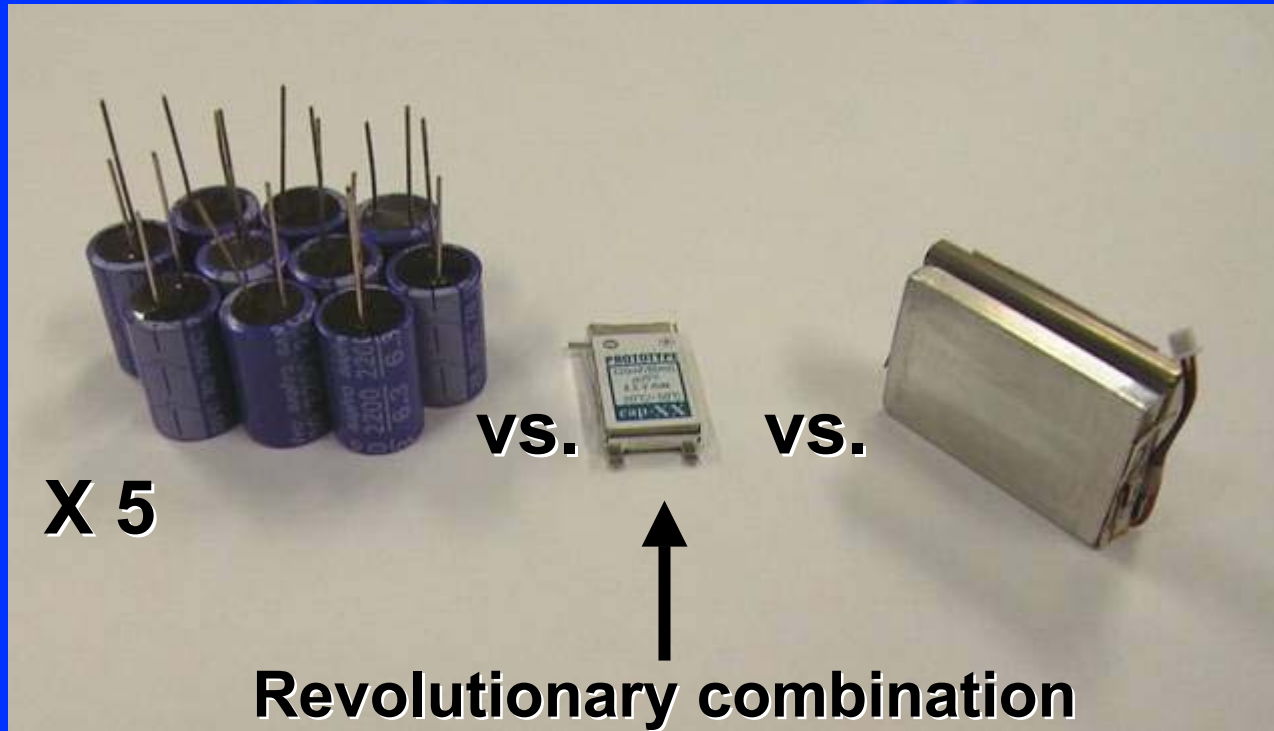

cap-XX: Digital power for next mobile generation

Users want longer run time from their notebook computers

## Problems for next mobile generation

### Issues

1. Power surges from the CPU cause voltage ripple in the battery
2. Sudden current loads from devices cause voltage droop on the battery
3. Transient power surges damage batteries
4. Lower voltage rails provide higher loads on batteries

### Problems

- Premature shut down
- Premature shut down
- Decrease in battery run time and battery life
- Decrease in battery run time and battery life

# cap-XX supercapacitor technology improves power management

## Problems

- ❑ Premature shut down
- ❑ Decreased battery run time
- ❑ Decreased battery life

## Key cap-XX benefits

- ❑ 86% lower voltage ripple preventing premature battery-driven shut down in notebooks (**demonstration**)
- ❑ Absorption of CPU and other power transients resulting in longer battery run time

**cap-XX: Digital power for next mobile generation**

Specific additional benefits arising from...

# The cap-XX mobile experience

- ❑ Backup to main power rail in power-on-suspend permitting battery hot swap (**demonstration**)
- ❑ -20°C operation where batteries struggle with power delivery
- ❑ Delivery of power surges for wireless connectivity resulting in adoption of lower cost energy dense batteries and other energy sources
- ❑ Delivery of power surges from increased functionality in mobile devices from the same energy source
- ❑ Thin & light solutions for power delivery saving space

*The following demonstrations come from the next mobile generation*

**cap-XX: Digital power for next mobile generation**

# Battery Hot-Swap Demonstration 1

- ❑ **Today's designs typically requires**
  - Complete system shutdown or Suspend to disk
    - Long Resume Time
  - AC Adapter presence
    - Inconvenient
- ❑ **cap-XX Supercapacitor provides hold-up charge for battery swapping with much faster resume time**

**cap-XX: Digital power for next mobile generation**

# Hot-Swap Demo Set Up

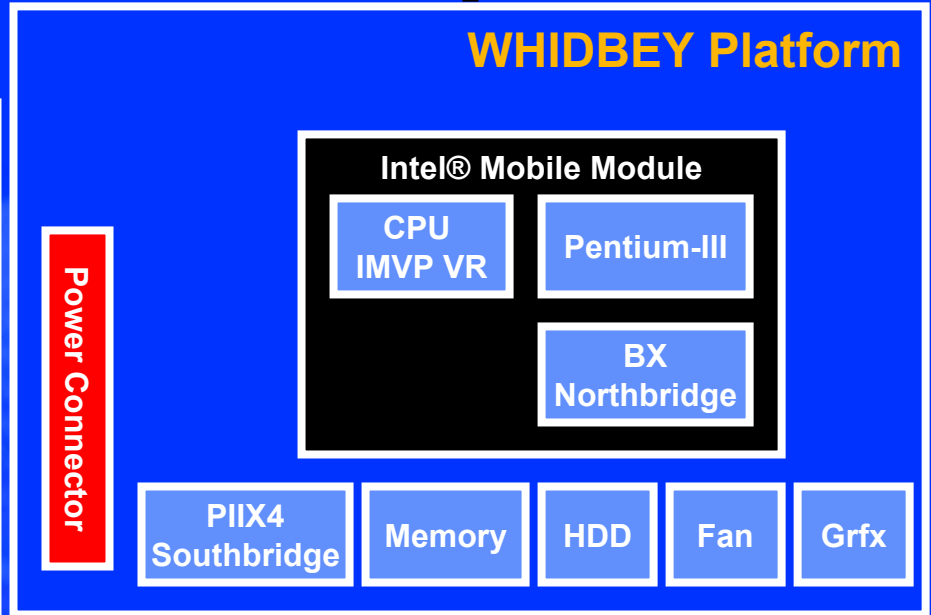

**cap-XX Supercap provides battery hot-swap**

**cap-XX: Digital power for next mobile generation**

# Mobile Power Delivery Demonstration 2

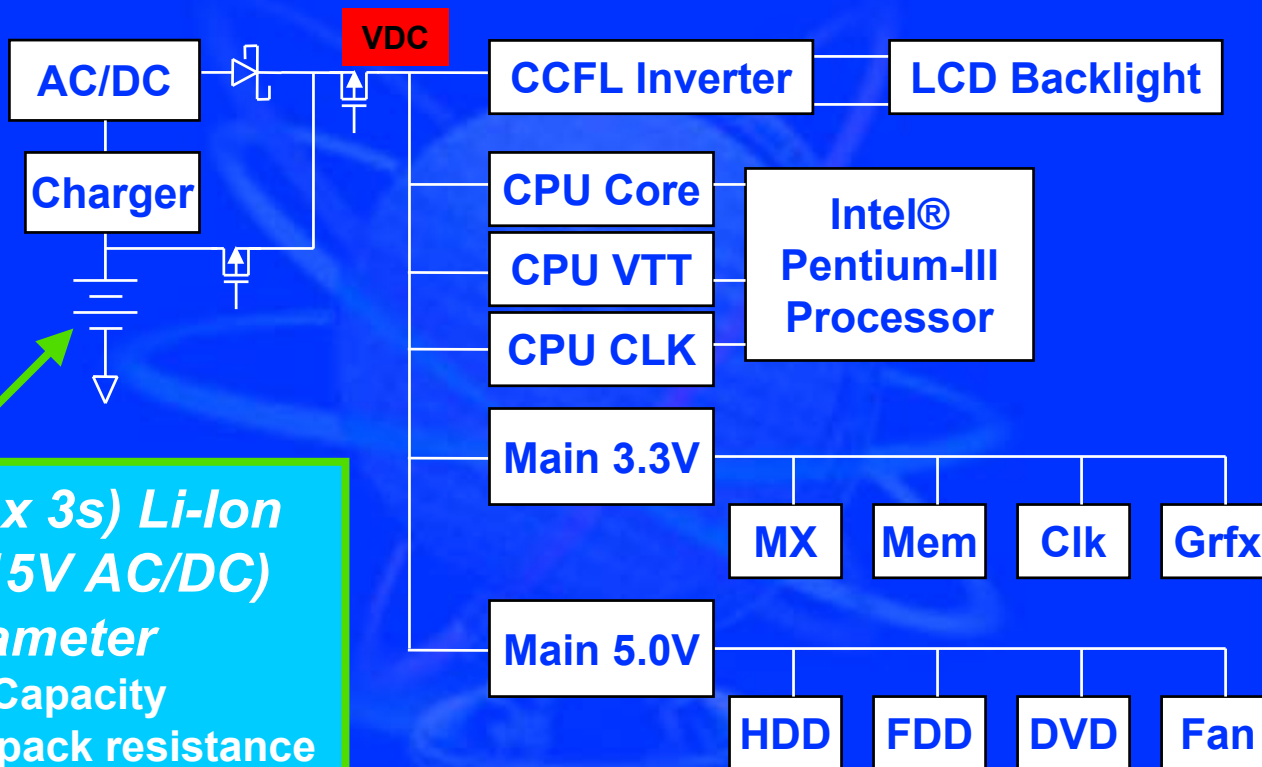

- 6-cell (2p x 3s) Li-Ion
- 9-12.6V (15V AC/DC)
- Pack Parameter
  - ✓ 40Whr Capacity
  - ✓ 105mΩ pack resistance

cap-XX: Digital power for next mobile generation

# CPU Power Delivery Model

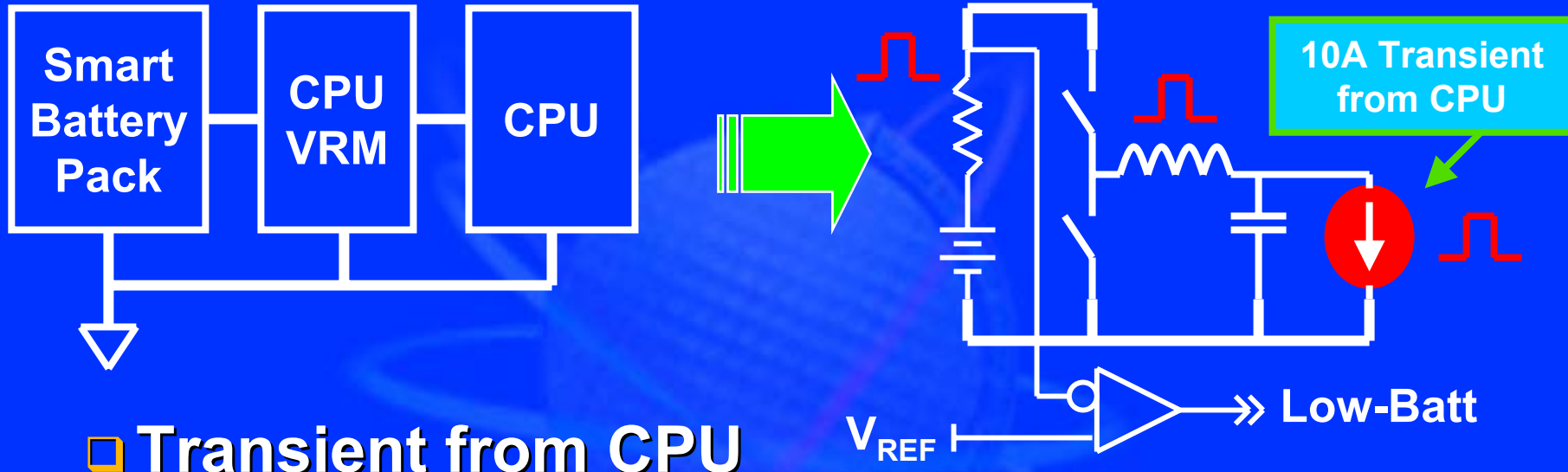

## ❑ Transient from CPU

- CPU Power Management Routine
- StpClk (Thermal Throttling), etc..

## ❑ Large Ripple Current in Battery from CPU

- Accidental (premature) Low-Batt Detection
- Premature System Shutdown

**Premature Shutdown = Loss of Battery Run Time**

**cap-XX: Digital power for next mobile generation**

# CPU Power Delivery Model

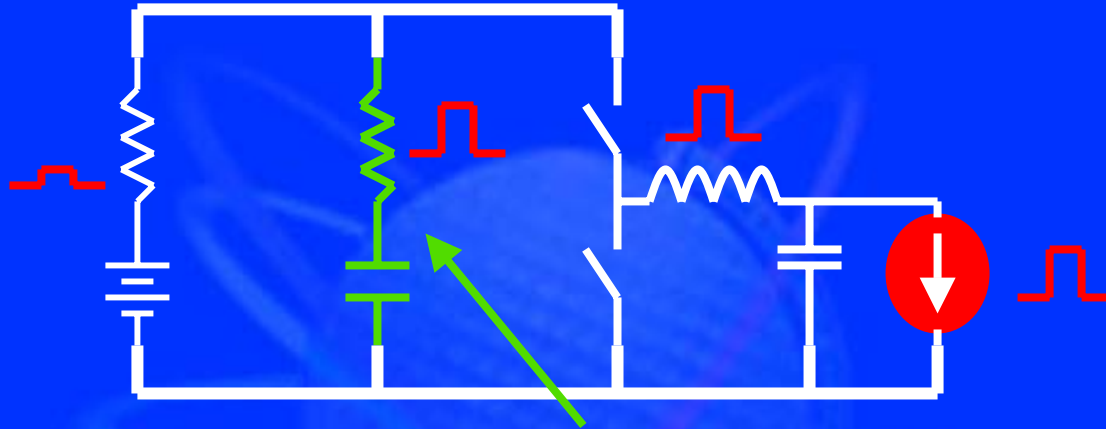

*cap-XX Supercapacitor*  
• ESR < 105 mΩ

- ❑ **cap-XX Supercapacitor absorbs CPU transient**
  - Much reduction of battery ripple current
  - Achieve more accurate Low-Battery Detection

**Supercapacitor = Increase of Battery Run Time**

**cap-XX: Digital power for next mobile generation**

# Mobile Power Delivery

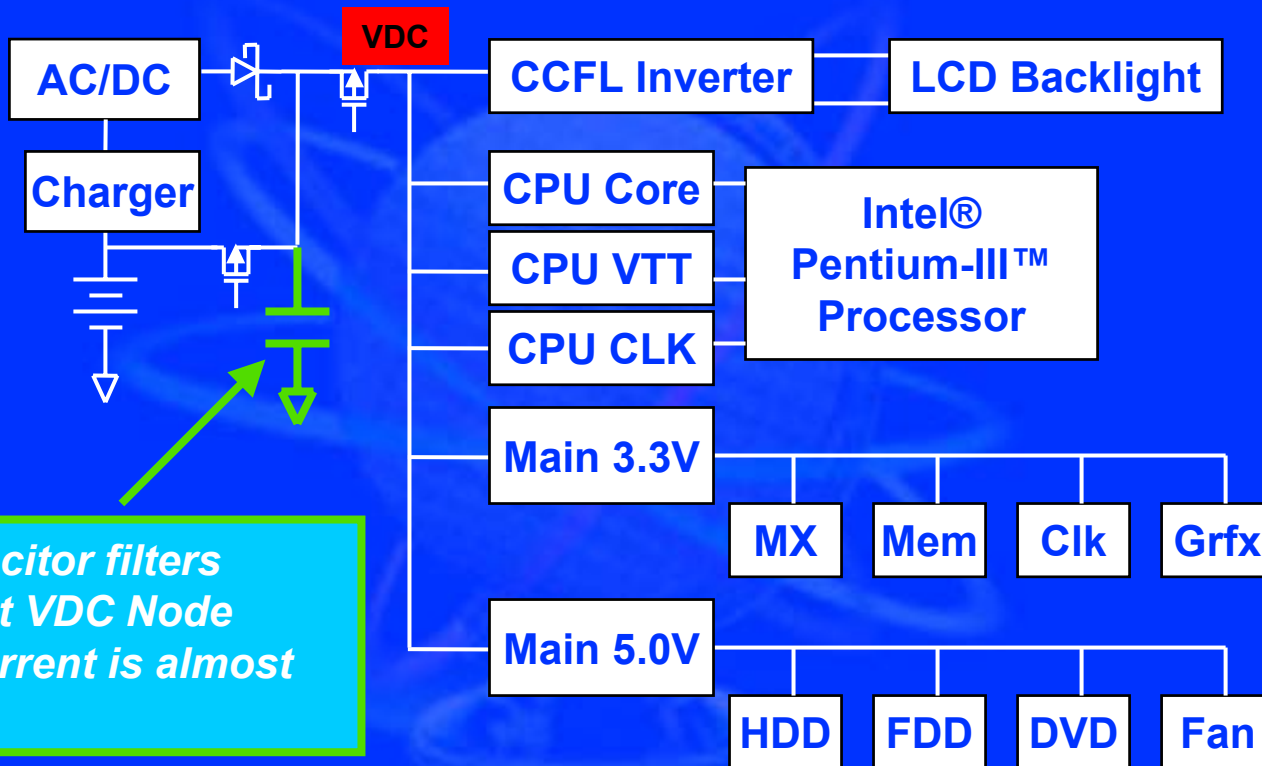

- Supercapacitor filters transient at VDC Node
- Battery Current is almost "DC"

cap-XX: Digital power for next mobile generation

# Transient Demo Set Up

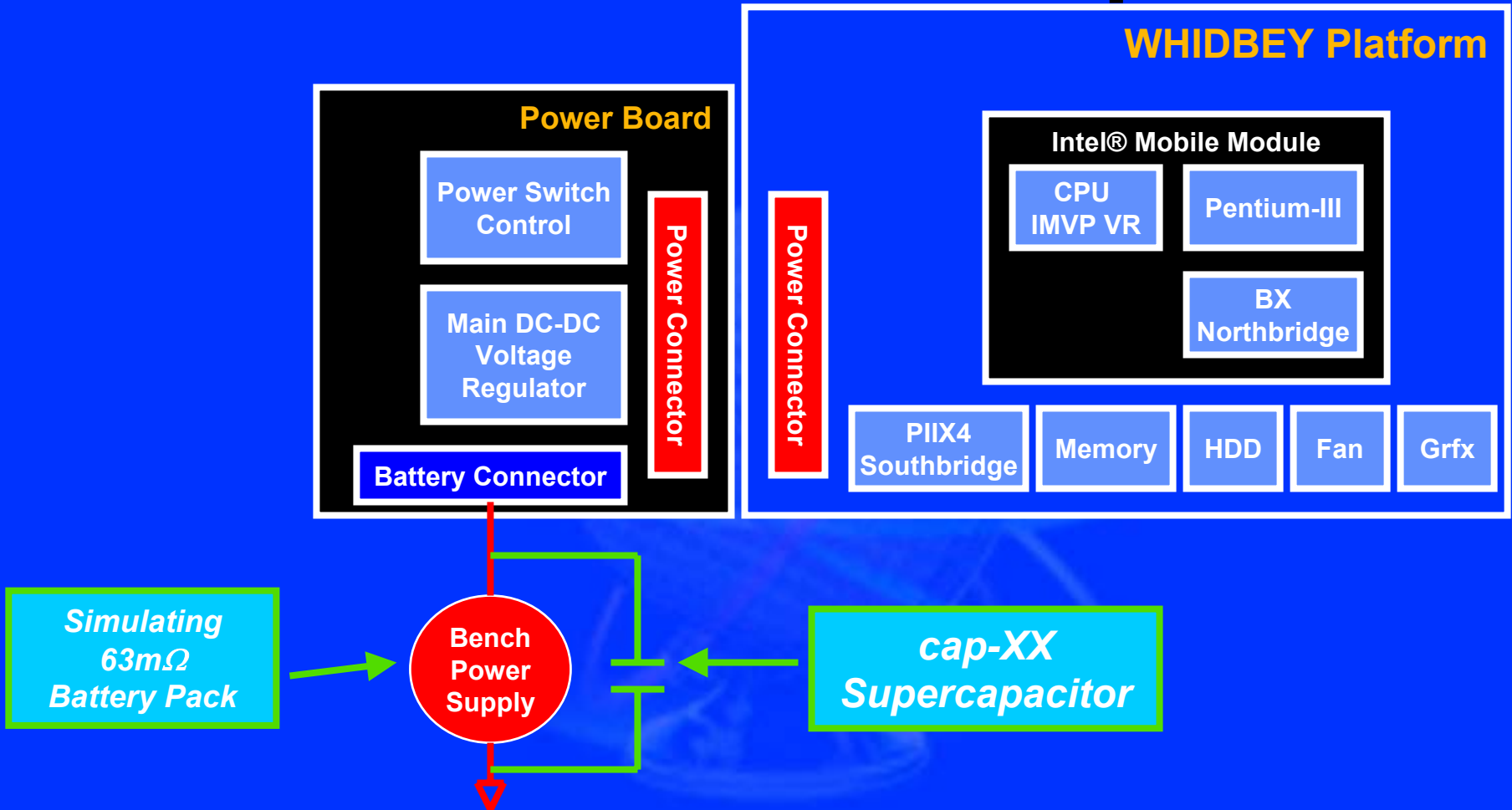

**cap-XX Supercapacitor filters transient current caused by system power management**

**cap-XX: Digital power for next mobile generation**

# Test Result

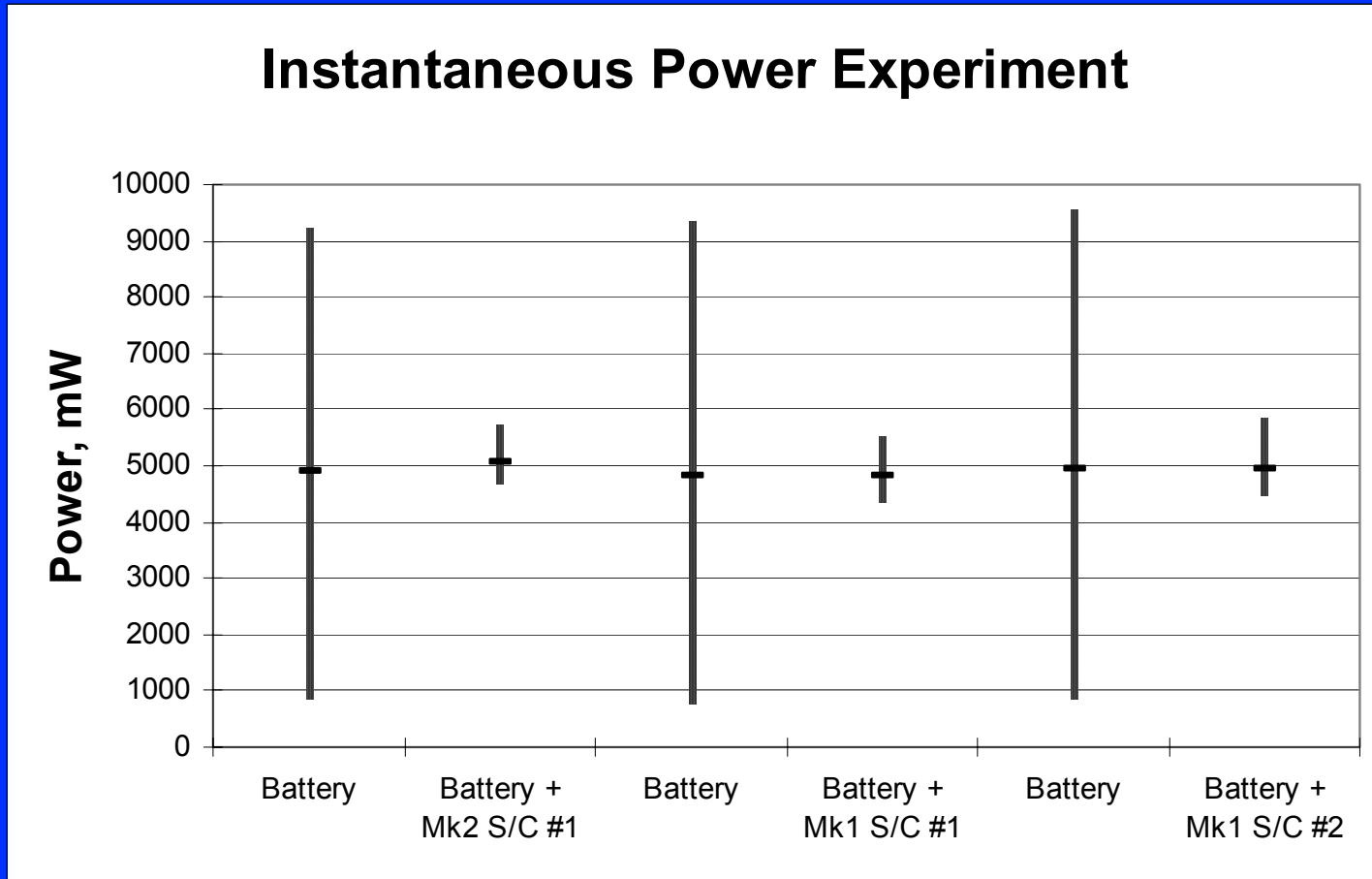

**cap-XX Supercapacitor REDUCES  
instantaneous power by 8x!**

**cap-XX: Digital power for next mobile generation**

# Test Result

**Without Supercapacitor**

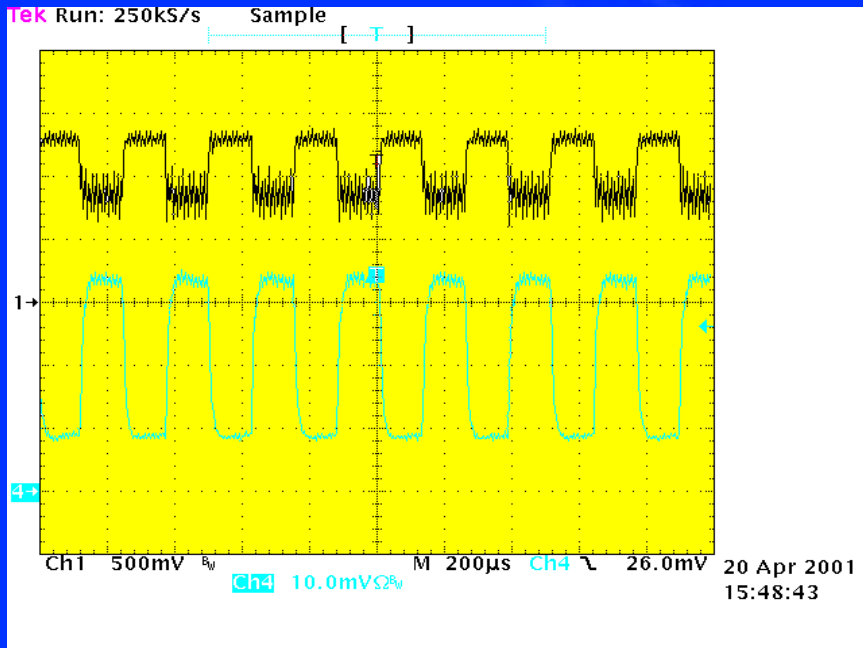

**With Supercapacitor**

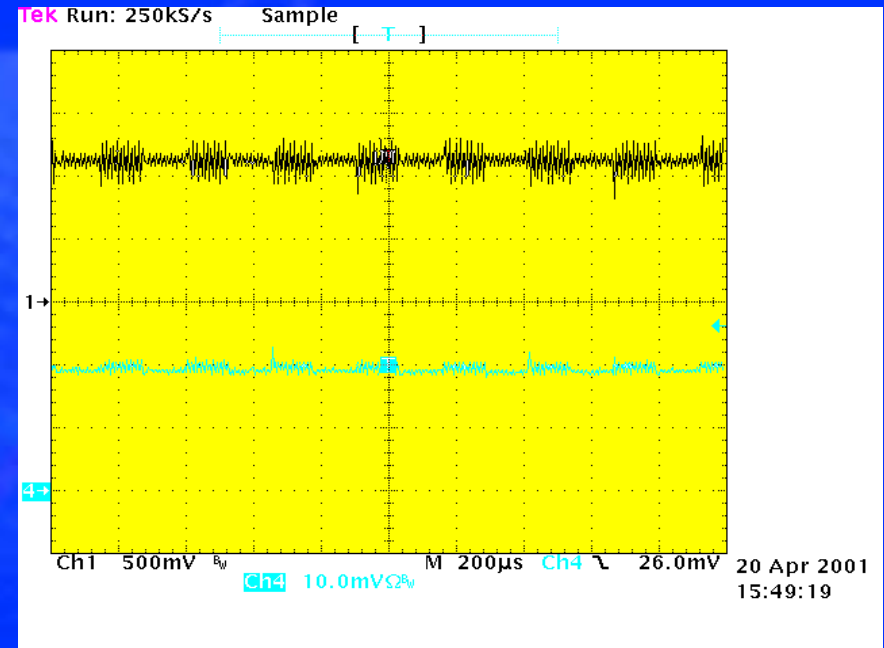

**cap-XX Supercapacitor REDUCES battery ripple voltage by 10x!**

**cap-XX: Digital power for next mobile generation**