



H Series Supercapacitors Product Bulletin

CAP-XX supercapacitors deliver outstanding power and energy performance in a number of footprints, configurations, voltage ratings and environmental specifications.

They are ideally suited to meet the peak power demands of pulsed loads in battery-powered electronics and many other consumer and industrial devices with a current-limited energy source.



H series (High Temperature) supercapacitors operate across an extended temperature range (-40°C to +85°C), and at a higher voltage (5.5V or 2.75V) than their G series counterparts. The 5.5V dual cell devices can operate directly off 5V rails such as USB, etc. The 2.75V single cell devices can be connected in series and mounted side by side to offer industrial designers the thinnest supercapacitor solution available. The H series is available in four footprints:

The **HS** range (39.0 x 17.0mm) offers the highest performance and most cost-effective solution to peak power and interim power demands in the most demanding environments and products, including ruggedized PDAs, solid state storage solutions and industrial condition monitoring units.

HW (28.5 x 17.0mm) offers a more compact footprint for use in handheld devices and smaller electronic products like modems, location trackers, audio accessories and security systems.

The **HA** series (20.0 x 18.0mm) is designed to meet the power requirements of high current LED flash in ultra-slim camera phones and digital cameras. With its rectilinear prismatic package and thinner materials, solutions are available with a height requirement of as little as 1.85mm.



The ultra-small **HZ** series (20.0 x 15.0mm) offers best-in-class performance and a diminutive footprint. With 5.5V capability and extended temperature rating, the HZ202 is ideally suited to GPRS support in the latest USB and ExpressCard modem designs.

Key benefits:

- Extended voltage & temperature ratings enable use in demanding environments
- Exceptional power density (~75kW/litre) and low ESR (from 50mΩ) support large peak loads
- High capacitance to sustain long power surges
- Very low leakage current to extend battery life
- Low ESR rise rate to ensure a long operational life
- Environmentally friendly, RoHS compliant and lead-free
- Thin, prismatic packaging for space-constrained applications

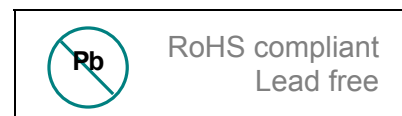

Reduce voltage drops and DC/DC requirements in consumer and industrial devices

Extend battery life, battery run-time and stand-by time, particularly at low temperatures

Protect against voltage transients (e.g., drop test) and short-term interruptions (e.g., last gasp, hot-swap, etc.)

Solve the current limitations of USB, PCI, PCMCIA & CF ports, and of long-life batteries, fuel cells, solar cells, etc.



H Series Supercapacitors

H Series Supercapacitors: Product Specifications					
Operating Voltage	Body Size	Product Name	Capacitance ¹ (± 20%) ²	ESR ¹ (± 20%) ²	Maximum Thickness
5.5V nominal (5.5V Maximum)	20.0 x 15.0mm	HZ 202F	90 mF	200 mΩ	3.00 mm
	20.0 x 18.0mm	HA 230F	400 mF	140 mΩ	3.80 mm
	28.5 x 17.0mm	HW 209F	140 mF	120 mΩ	2.20 mm
		HW 202F	220 mF	90 mΩ	3.00 mm
		HW 201F	350 mF	120 mΩ	2.50 mm
	39.0 x 17.0mm	HW 203F	550 mF	90 mΩ	3.50 mm
		HS 203F	250 mF	70 mΩ	2.20 mm
		HS 211F	370 mF	50 mΩ	3.00 mm
		HS 206F	600 mF	70 mΩ	2.50 mm
			HS 208F	900 mF	50 mΩ
		HS 230F	1200 mF	50 mΩ	3.80 mm
2.75V nominal (2.75V Maximum)	20.0 x 15.0mm	HZ 102F	180 mF	100 mΩ	1.45 mm
	20.0 x 18.0mm	HA 130F	800 mF	70 mΩ	1.85 mm
	28.5 x 17.0mm	HW 109F	280 mF	60 mΩ	1.10 mm
		HW 102F	440 mF	45 mΩ	1.45 mm
		HW 101F	700 mF	60 mΩ	1.20 mm
	39.0 x 17.0mm	HW 103F	1100 mF	45 mΩ	1.70 mm
		HS 103F	500 mF	36 mΩ	1.10 mm
		HS 111F	740 mF	26 mΩ	1.45 mm
		HS 106F	1200 mF	36 mΩ	1.20 mm
			HS 108F	1800 mF	26 mΩ
		HS 130F	2400 mF	26 mΩ	1.85 mm

Parameter	Minimum	Nominal	Maximum
Operating Temp	-40°C	+25°C	+85°C
Storage Temp	-40°C	+25°C	+85°C
Leakage Current ³		1µA	2µA
Pulse Current	30A (single pulse. +ve & -ve terminal short circuited)		
ESR change with Temp	75% of nominal @ +70°C		150% of nominal @ -20°C

Notes

1. Capacitance will decline and ESR will rise over time, at a rate which depends on both voltage and temperature. Operation at +85°C and 5.5V concurrently will shorten life and is not recommended for extended periods. Contact CAP-XX for more.
2. DC capacitance and ESR tolerance are measured at +25°C
3. Leakage current is measured after 72h at voltage at +25°C
4. Single cell products are special order

For more on CAP-XX products, go to www.cap-xx.com or contact us by email at sales@cap-xx.com.



H Series Supercapacitors

HS Dual Cell Devices - Mechanical & Electrical Drawings

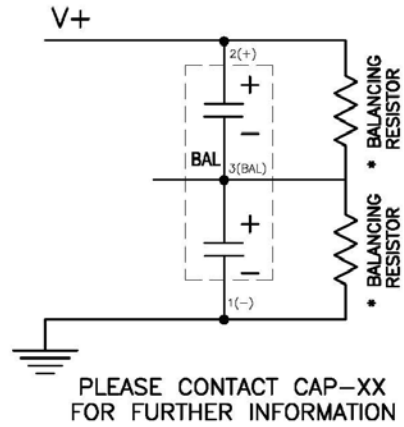
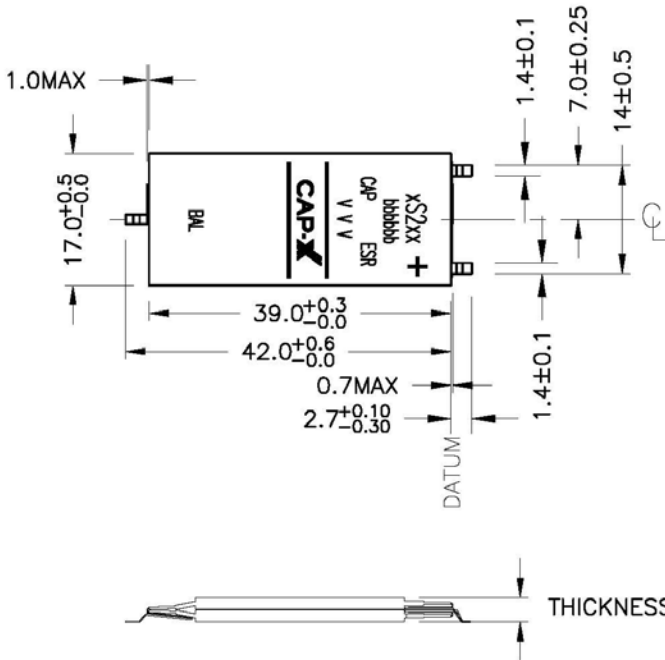

SUGGESTED CONNECTION DETAILS FOR 2 - CELL SUPERCAP

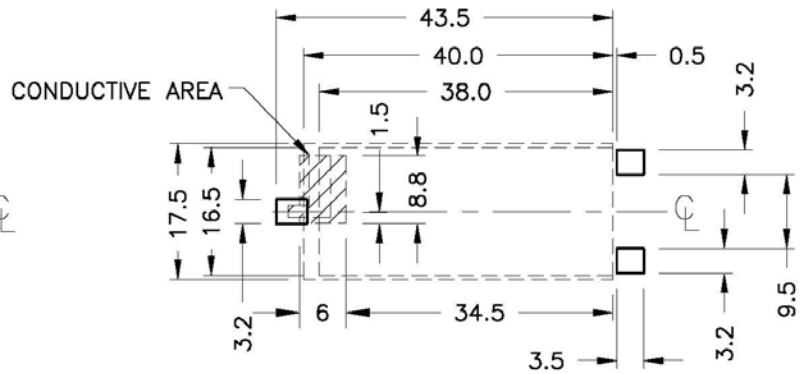
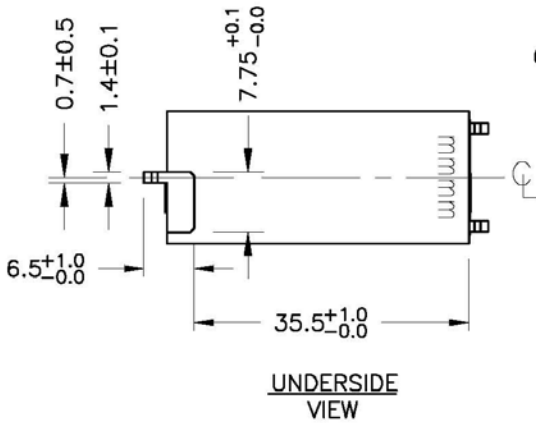

SUGGESTED PAD LAYOUT

THE PAD SIZE SHOWN IS BASED ON CAP-XX MANUFACTURING TOLERANCES. THE FINAL PAD SIZE SHOULD ALLOW FOR CUSTOMER MANUFACTURING (PLACEMENT) TOLERANCES.

Note: Refer Product Specification for thickness and print values XX, bbbbbb, CAP, ESR, mmmm



H Series Supercapacitors

HW Dual Cell Devices - Mechanical & Electrical Drawings

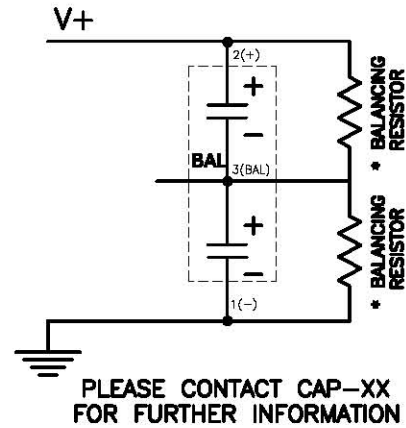
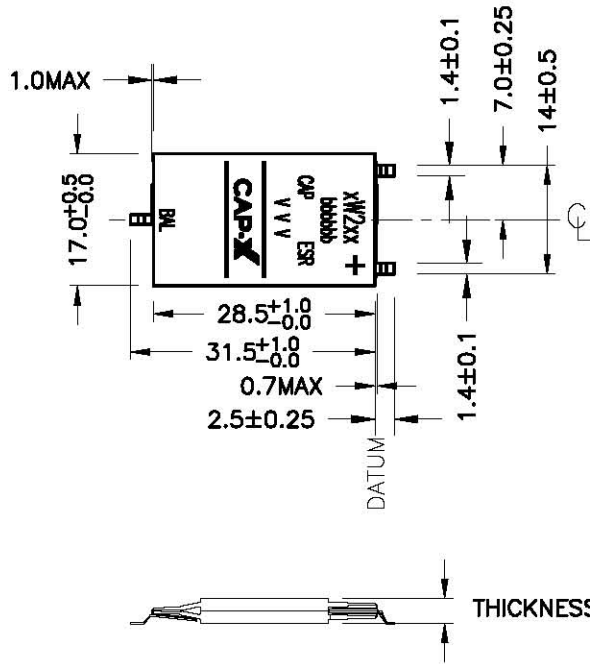

**SUGGESTED CONNECTION
 DETAILS FOR 2 - CELL
 SUPERCAP**

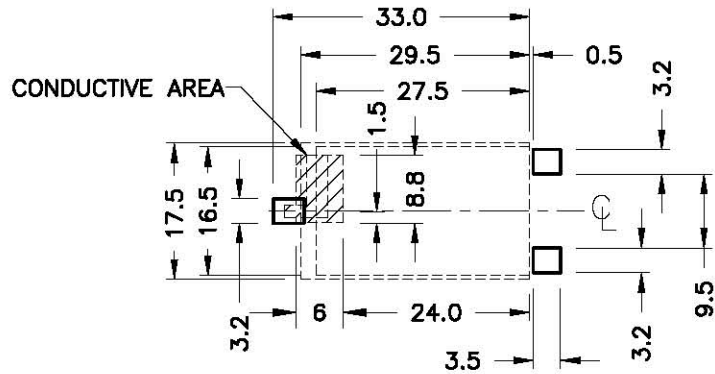
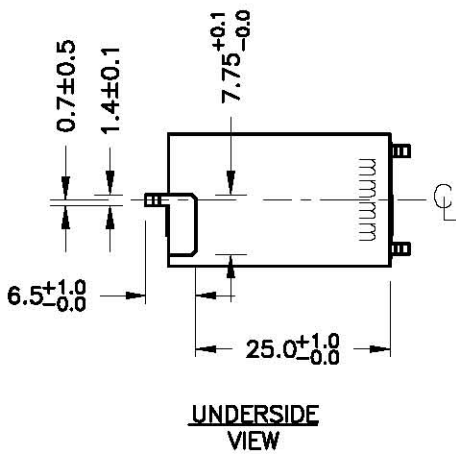

SUGGESTED PAD LAYOUT

THE PAD SIZE SHOWN IS BASED ON CAP-XX MANUFACTURING TOLERANCES. THE FINAL PAD SIZE SHOULD ALLOW FOR CUSTOMER MANUFACTURING (PLACEMENT) TOLERANCES.

Note: Refer Product Specification for thickness and print values XX, bbbbbb, CAP, ESR, mmmm



H Series Supercapacitors

HA Dual Cell Devices - Mechanical & Electrical Drawings

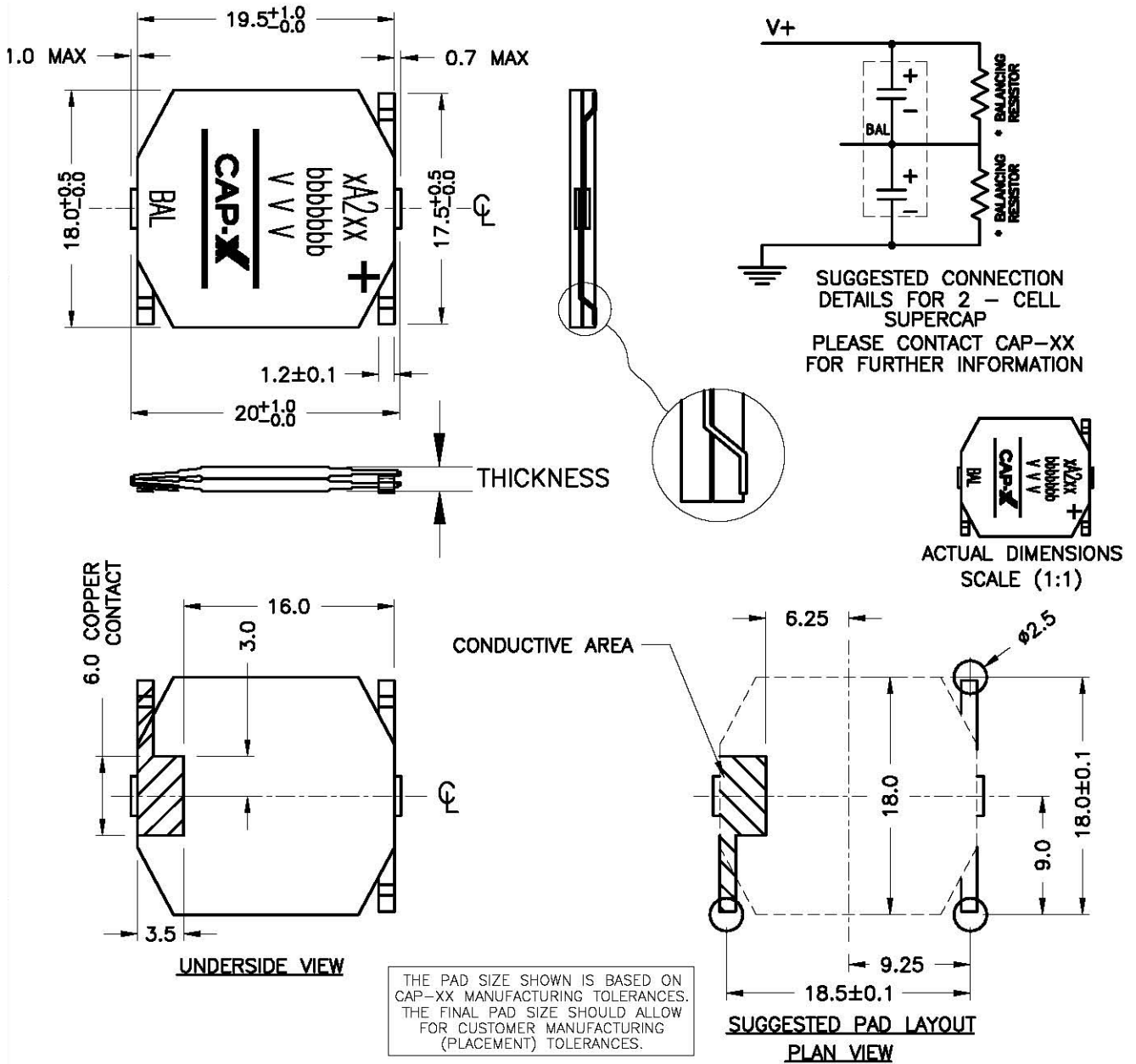



H Series Supercapacitors

HZ Dual Cell Devices - Mechanical & Electrical Drawings

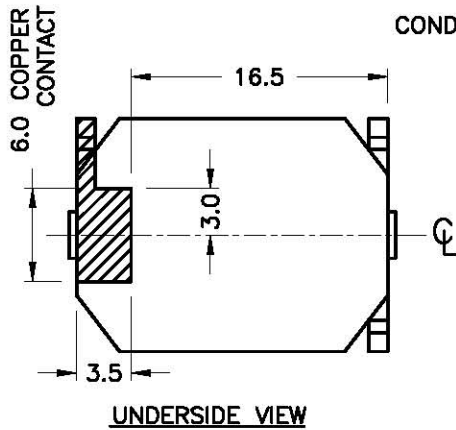
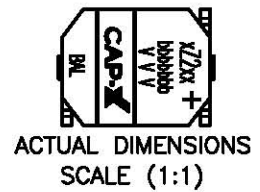
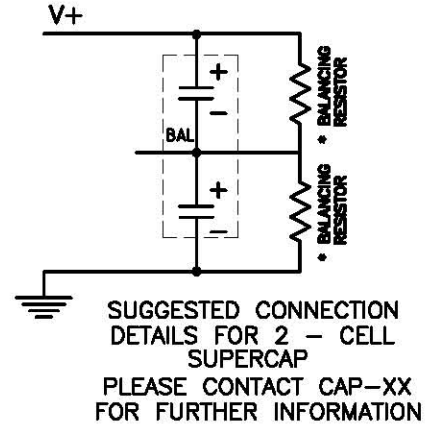
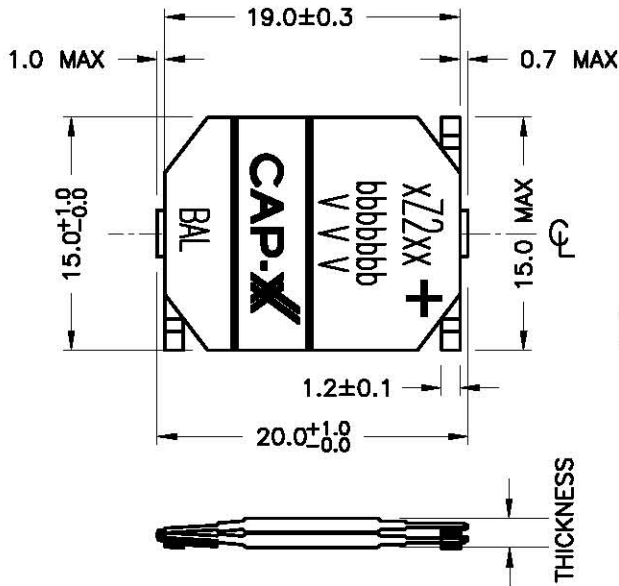

CONDUCTIVE AREA

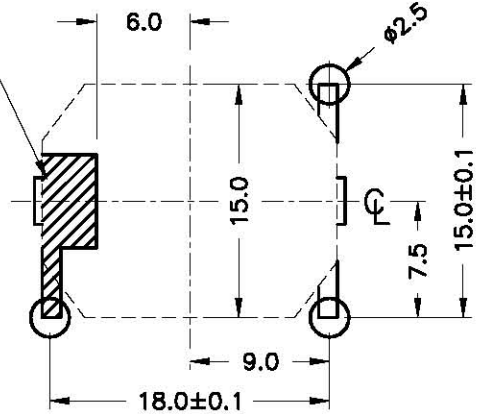

THE PAD SIZE SHOWN IS BASED ON CAP-XX MANUFACTURING TOLERANCES. THE FINAL PAD SIZE SHOULD ALLOW FOR CUSTOMER MANUFACTURING (PLACEMENT) TOLERANCES.



H Series Supercapacitors

HS Single Cell Devices - Mechanical & Electrical Drawings

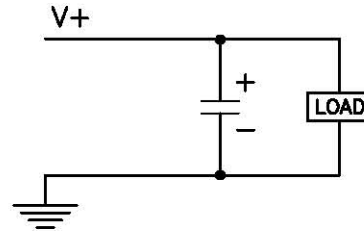
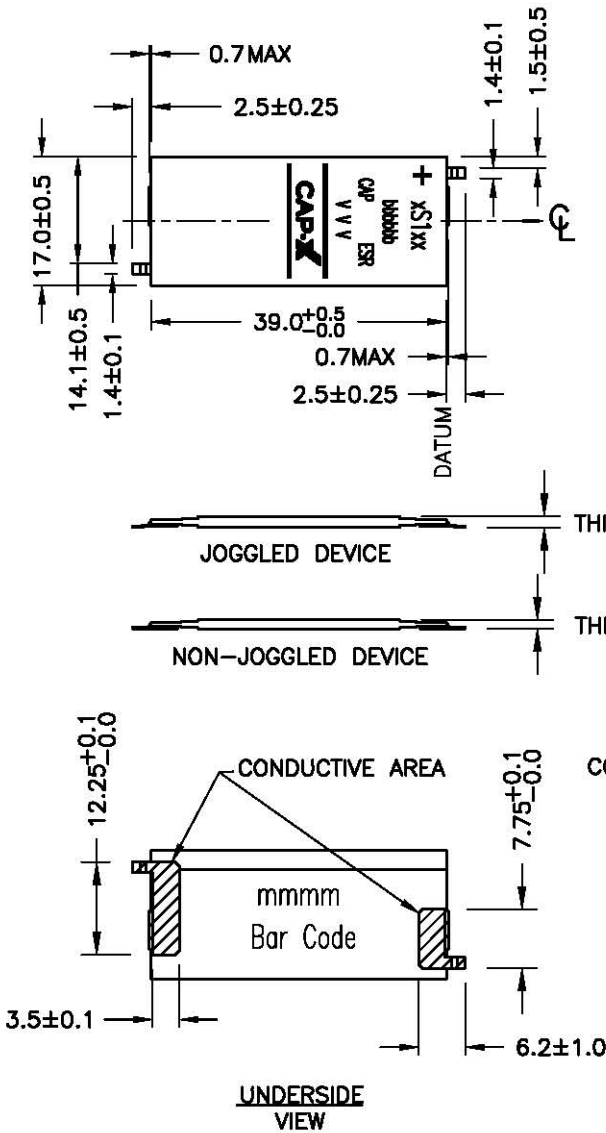

PLEASE CONTACT CAP-XX FOR FURTHER INFORMATION

SUGGESTED CONNECTION DETAILS FOR SINGLE CELL SUPERCAP

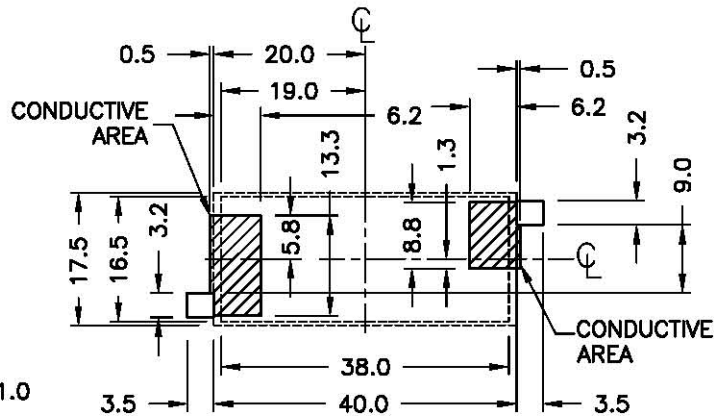

SUGGESTED PAD LAYOUT

THE PAD SIZE SHOWN IS BASED ON CAP-XX MANUFACTURING TOLERANCES. THE FINAL PAD SIZE SHOULD ALLOW FOR CUSTOMER MANUFACTURING (PLACEMENT) TOLERANCES.

Note: Refer Product Specification for thickness and print values XX, bbbbbb, CAP, ESR, mmmm



H Series Supercapacitors

HW Single Cell Devices - Mechanical & Electrical Drawings

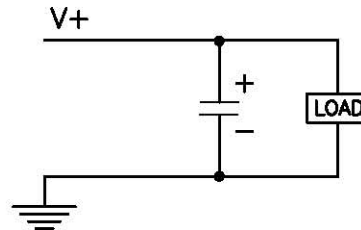
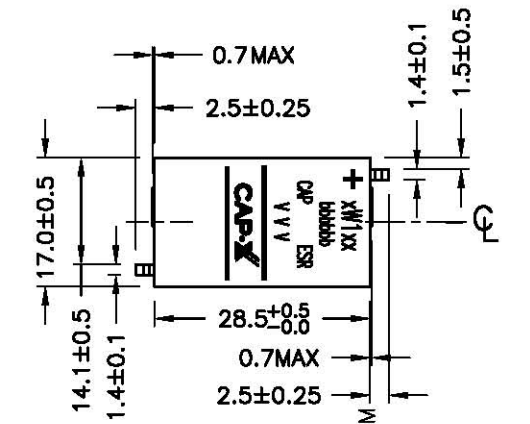

PLEASE CONTACT CAP-XX FOR FURTHER INFORMATION

SUGGESTED CONNECTION DETAILS FOR SINGLE CELL SUPERCAP

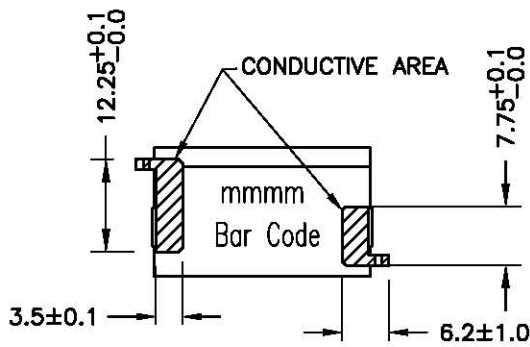
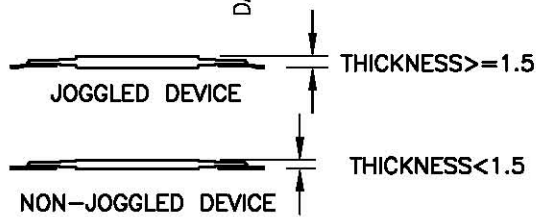

UNDERSIDE VIEW

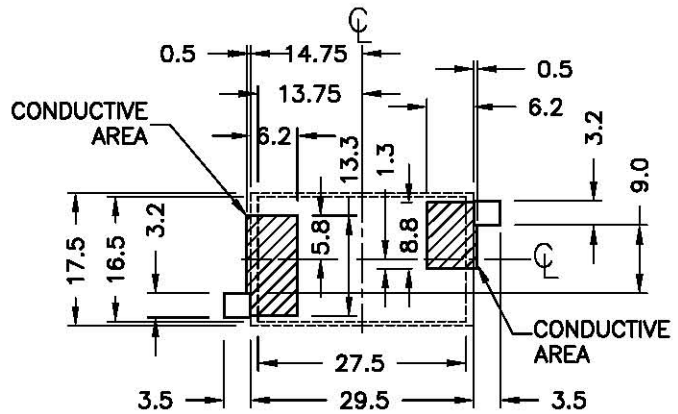

SUGGESTED PAD LAYOUT

THE PAD SIZE SHOWN IS BASED ON CAP-XX MANUFACTURING TOLERANCES. THE FINAL PAD SIZE SHOULD ALLOW FOR CUSTOMER MANUFACTURING (PLACEMENT) TOLERANCES.

Note: Refer Product Specification for thickness and print values XX, bbbbbb, CAP, ESR, mmmm



H Series Supercapacitors

HZ Single Cell Devices - Mechanical & Electrical Drawings

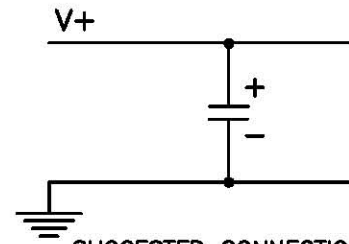
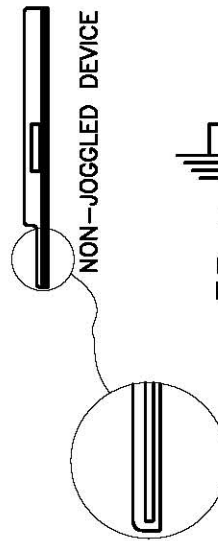
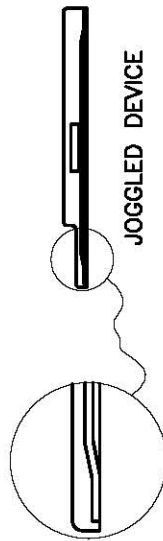
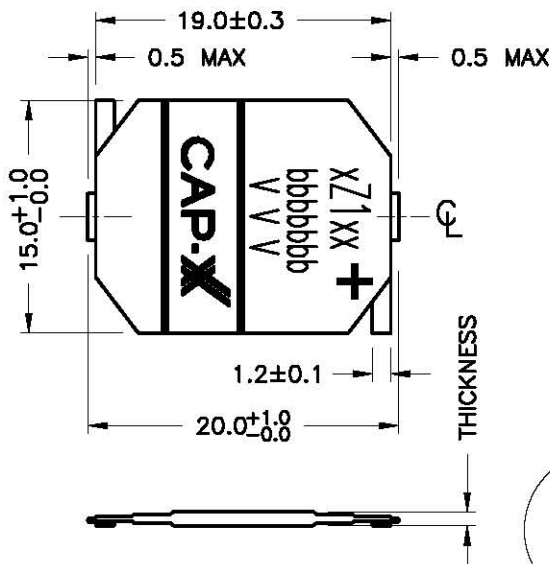

SUGGESTED CONNECTION
DETAILS FOR SINGLE CELL
SUPERCAP
PLEASE CONTACT CAP-XX
FOR FURTHER INFORMATION

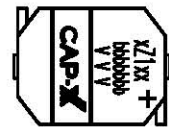

ACTUAL DIMENSIONS
SCALE (1:1)

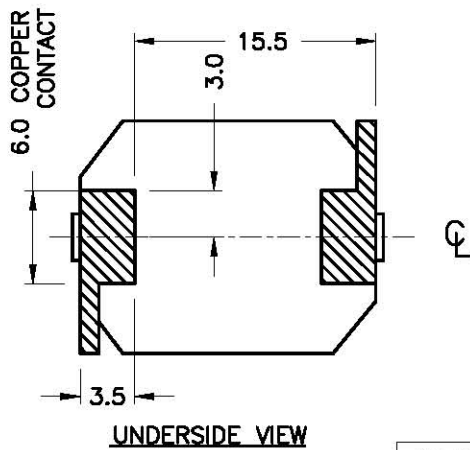

UNDERSIDE VIEW

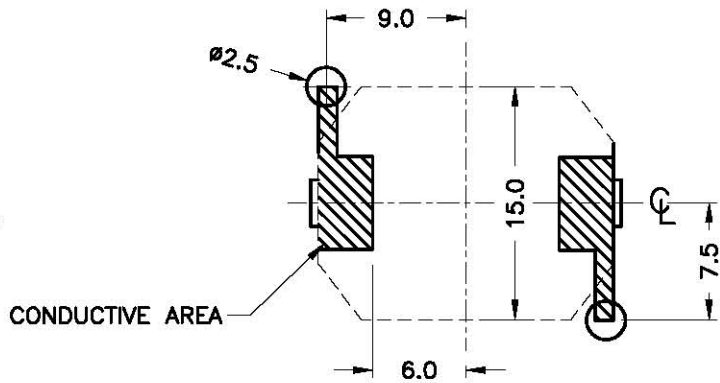

SUGGESTED PAD LAYOUT
PLAN VIEW

THE PAD SIZE SHOWN IS BASED ON
CAP-XX MANUFACTURING TOLERANCES.
THE FINAL PAD SIZE SHOULD ALLOW
FOR CUSTOMER MANUFACTURING
(PLACEMENT) TOLERANCES.